

Henkjan Honing

Musicality as an Upbeat to Music

1

Musicality as an Upbeat to Music: Introduction and Research Agenda

Henkjan Honing

Over the years, it has become clear that all humans share a predisposition for music, just like we have for language. We all can perceive and enjoy music. This view is supported by a growing body of research from developmental psychology (Trainor, 2008; Trehub, 2003), cognitive biology (Fitch, 2006; Wilson & Cook, 2016), neuroscience (Peretz & Coltheart, 2003; Peretz & Zatorre, 2005; Zatorre, 2005), and the many contributions from the field of music cognition (Deutsch, 2013; Hallam, Cross, & Thaut, 2009). These studies indicate that our capacity for music has an intimate relationship with our cognition and underlying biology, which is particularly clear when the focus is on perception rather than production (Honing, 2013).

Until relatively recently, most scholars were wary of the notion that music cognition could have a biological basis. Instead, music was viewed as a cultural product with no evolutionary history and no biological constraints on its manifestation (e.g., Repp, 1991). Such a view is indicative of a Western perspective on music, in which music is viewed as the preserve of professional musicians who have honed their skills through years of practice (Blacking, 1973). Obviously such notions do not explain the presence of music in all cultures and time periods, let alone other species. There is increasing evidence that all humans, not just highly trained individuals, share a predisposition for music in the form of musicality—defined as a spontaneous developing set of traits based on and constrained by our cognitive abilities and their underlying biology. To recognize a melody and perceive the beat of music are trivial skills for most humans, but they are in fact fundamental features of our musicality (Honing, 2012; Trehub, 2003). Even infants are sensitive to such features, which are common across cultures (Savage, Brown, Sakai, & Currie, 2015; Trehub, 2015). Though we are learning more and more about our own musicality (Deutsch, 2013; Fitch, 2006; Honing, 2013), the cognitive and biological mechanisms underlying it remain unclear.

The aim of this book is to identify the cognitive, biological, and mechanistic underpinnings for melodic and rhythmic cognition as key ingredients of musicality, assess to what extent these are unique to humans, and by doing so

provide insight in their biological origins. Our aspiration as editor and chapter authors is that this book will lay a new interdisciplinary and comparative foundation for the study of musicality.

The key ingredients for this endeavor were generated at the Lorentz workshop, “What Makes Us Musical Animals?” that was held in April 2014 in Leiden, the Netherlands (see the Preface, this volume, for more details). This workshop aimed to assemble the key ingredients for a research agenda on musicality and thus provided the impetus for this book as a whole.

Before outlining this research agenda and relating its key ingredients to the chapters that follow, I present some preliminaries on the interdisciplinary field of musicality.

Music versus Musicality

Within any given culture, people agree, more or less, on what constitutes music. However, there is considerably less agreement across cultures (see chapter 6, this volume). Venturing across species caused even more debate. Though some people agree that the songs of birds, humpback whales, a Thai elephant orchestra, or the interlocking duets of gibbons are instances of music (Wallin, Merker, & Brown, 2000), others would argue instead that human listeners use a musical frame of reference that makes many things seem musical (Honing, 2013).

Addressing these issues productively requires a distinction between the notions of music and musicality (Honing & Ploeger, 2012; Morley, 2013; Trehub, 2003). *Musicality* in all its complexity can be defined as a natural, spontaneously developing set of traits based on and constrained by our cognitive and biological system. *Music* in all its variety can be defined as a social and cultural construct based on that very musicality. As such, the study of the origins of music is conditional on the study of musicality.

One approach in the investigation of the origins of music is to study the structure of music, seeking key similarities and differences of musical form and activity in a variety of human cultures (Brown & Jordania, 2011; Brown et al., 2014; Lomax & Berkowitz, 1972; Nettl, 2006; Savage et al., 2015). Although there is no widely shared definition of music, the presence of several cross-cultural similarities supports the notion of musicality as a prominent characteristic of humankind. These similarities are suggestive of underlying cognitive and biological mechanisms that may constrain and shape musical behaviors across cultures (Savage et al., 2015; Trehub, 2015).

An alternative approach is to study the structure of musicality by attempting to identify the basic underlying cognitive and biological mechanisms, their function and developmental course, and effective ways to study these mechanisms in human and nonhuman animals (Honing, ten Cate, Peretz, &

Trehub, 2015). The major challenge of this approach, and hence of this book, is to delineate the traits that constitute the musicality phenotype.

A Multicomponent Approach to Musicality

Certain cognitive capacities such as language and music are viewed as typically human. However, we still know very little about whether other species share one or more of the basic mechanisms that constitute musicality. Revealing such common mechanisms requires employing a bottom-up perspective focusing on the constituent capacities underlying musicality. Instead of asking which species are musical, we should ask how musicality works, what the necessary components of musicality are, which ones are shared with other species, and how they evolved. Such an approach has resulted in important insights into the domains of animal cognition (Call & Tomasello, 2008; de Waal & Ferrari, 2010, 2012) and the evolution of language (Fitch, 2010). Interestingly, all participants of the 2014 workshop on musicality quickly agreed on the importance of a multicomponent approach (see also chapter 2, this volume).

A multicomponent perspective aims to combine functional, developmental, phylogenetic, and mechanistic approaches in order to generate an integrated theory of musicality while focusing on the constituent capacities underlying the musicality phenotype. This can be addressed by using the four

explanatory levels that Tinbergen (1963) posited, describing the mechanisms, functions, and developmental course of musicality in a variety of animals and cultures, with input from anthropological, neuroscientific and genetic sources, and consequently examining in greater depth how music evolved.

This multicomponent approach is based on the neo-Darwinian assumption that if closely related species (e.g., humans and apes or walruses and sea lions) exhibit similar solutions to similar problems, they are probably engaging similar mechanisms (see figure 1.1). When two such species share a particular musical trait, one can infer that their common ancestor also had that trait. By examining these homologous traits in a natural group of species (i.e., clade), one can date the origin of that particular trait. Species that are closely related to humans can be assumed to share some cognitive abilities and may therefore be good models for experiments to tease apart various neurological, genetic, or epigenetic contributions to a certain musical trait. This is the principal motivation for studying musicality in closely related species (see chapters 7 and 8, this volume). The most promising group for such comparative research are monkeys (e.g., macaques or marmosets), a well-known animal model that, because of its homology, has been instrumental in understanding human brain function in domains ranging from audition and vision (Mendoza & Merchant, 2014) to language and music (see chapter 8, this volume; Rilling et al., 2008).

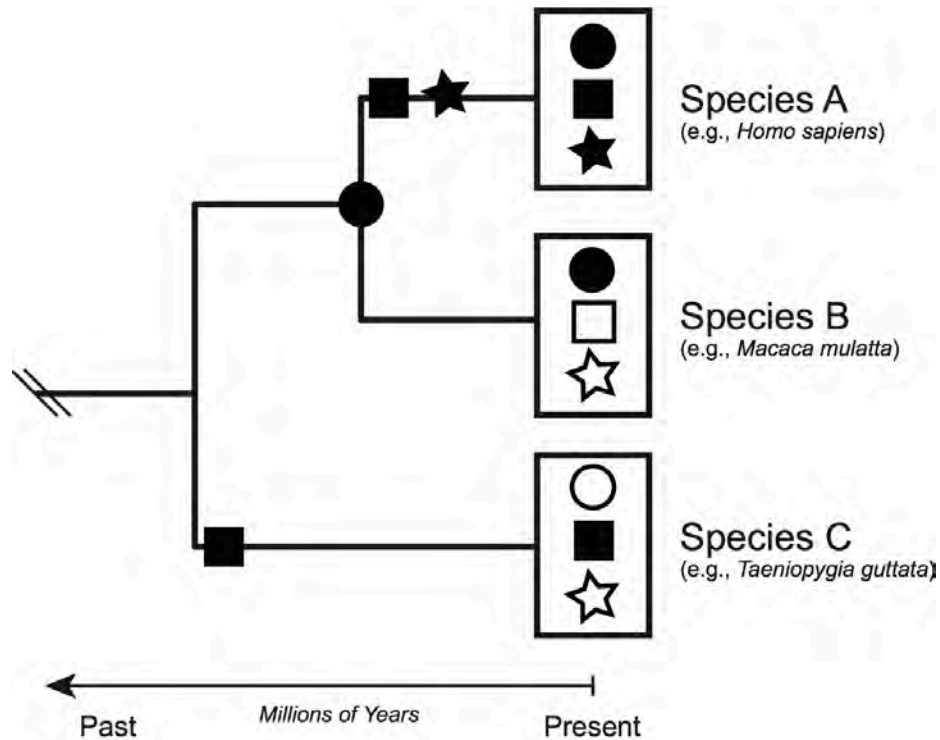

Figure 1.1. Neo-Darwinian perspective on the evolution of musicality.

Diagrammatic representation of a hypothetical phylogenetic tree illustrating the Darwinian assumption that closely related species share similar traits. When two species (A and B) share a certain musical trait, one can infer that their common ancestor (CA) also had that trait (referred to as a homologous trait). Filled circles represent a trait; open circles indicate the absence of that trait.

The study of more distant or unrelated species that share a similar trait (i.e., not homologous) can also contribute to an understanding of underlying mechanisms. The convergent evolution of particular traits in distant species (analogous trait; a form of homoplasy) will therefore allow identification of the biological

constraints or mechanisms required for that trait, as well as yielding hypotheses for the selection pressures giving rise to it (see [figure 1.2](#)). Birds are arguably the most promising group for such comparative research. Many bird species produce vocalizations characterized by brief elements (“notes”) of varying complexity and frequency and often structured with rhythmic regularity. Various bird species (e.g., starlings, zebra finches, budgerigars) are extensively studied for their auditory perceptual abilities, and studying their perception of musically inspired stimuli ([Spierings & ten Cate, 2014](#); [ten Cate, Spierings, Hubert, & Honing, 2016](#)) has contributed a lot to current ideas about the apparent uniqueness of human musicality.

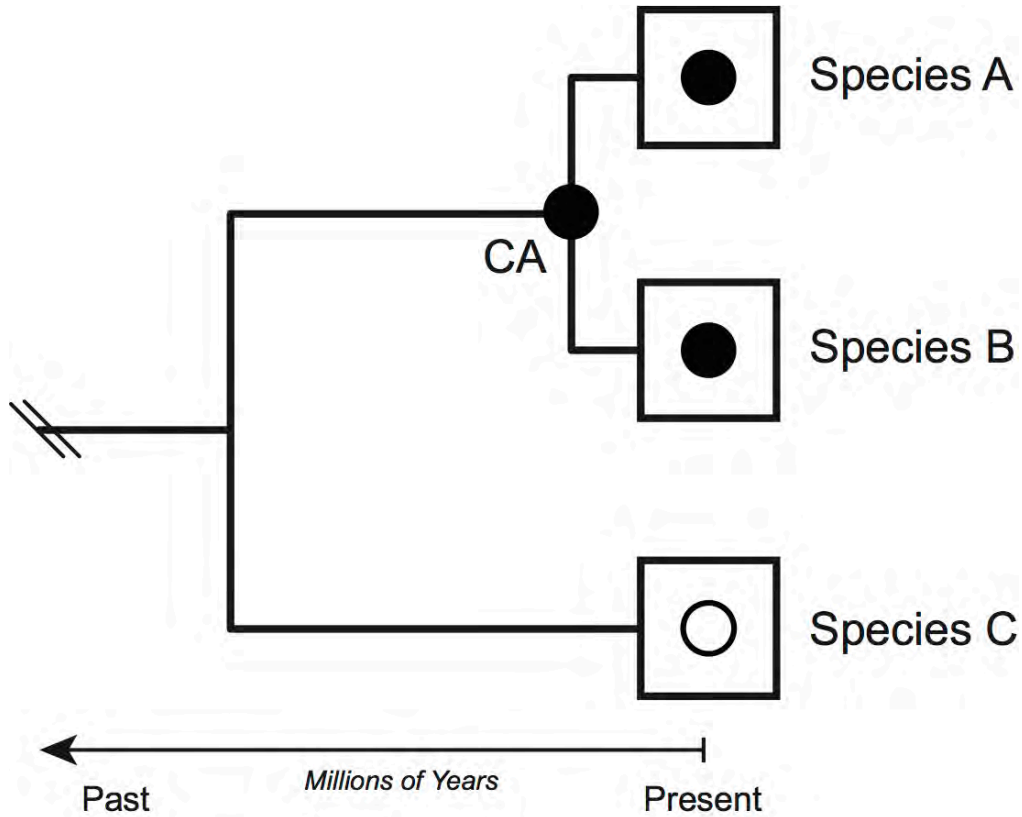

Figure 1.2. *Convergent evolution of musicality. Diagrammatic representation of a hypothetical phylogenetic tree illustrating an analogous trait (homoplasy) in which a distant species (C compared to A) developed a musical trait that is lacking in a more closely related species (B compared to A). Filled circles represent a trait; open circles indicate the absence of that trait.*

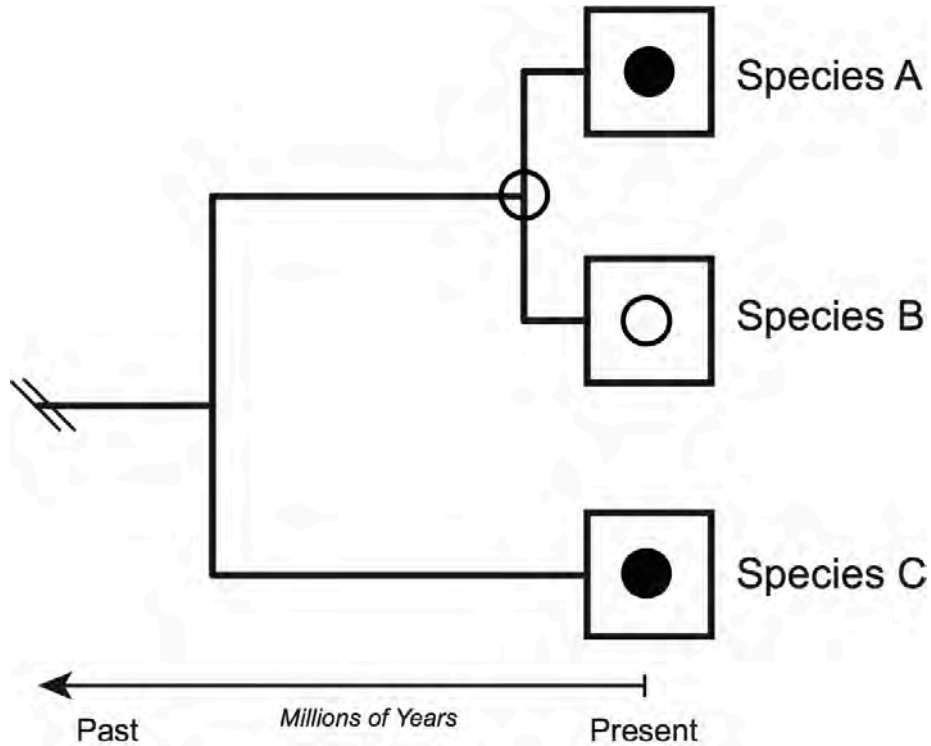

Figure 1.3. *Multicomponent perspective on musicality. Diagrammatic representation of the structure and evolution of musicality, illustrating the hypothesized contributions of several traits to musicality as a complex or multicomponent phenotype. Shaded shapes represent a single trait; open shapes indicate the absence of that same trait. The positions of shapes on the tree stand for the hypothesized dates of origin of those traits.*

Core Components of Musicality

Potential candidates for the basic components of musicality that have been proposed in the recent literature are relative pitch (e.g., contour and interval analysis; Justus & Hutsler, 2005; Trehub, 2003), regularity and beat perception (Honing, 2012; ten Cate et al., 2016), tonal encoding of pitch (Hoeschele, Cook, Guillette, Hahn, & Sturdy, 2014; Peretz & Coltheart, 2003), and metrical encoding of rhythm (Fitch, 2013b; Winkler, Háden, Ladinig, Sziller, & Honing, 2009). Some of these musical traits may be common to humans and other species, and others might be uniquely human (see figure 1.4). A comparative approach using well-known animal models, such as the rhesus macaque (*Macaca mulatta*) and the zebra finch (*Taeniopygia guttata*), offers a promising strategy for studying these components. Although only humans appear to possess the full suite of abilities that constitutes musicality, some core components may be evident in closely related species, implying biological precursors or, in distantly related species, implying convergent evolution. This will inform a phenomics of musicality (see chapter 10, this volume) and facilitate the development of an integrated neurocognitive model of musicality (see chapter 9, this volume).

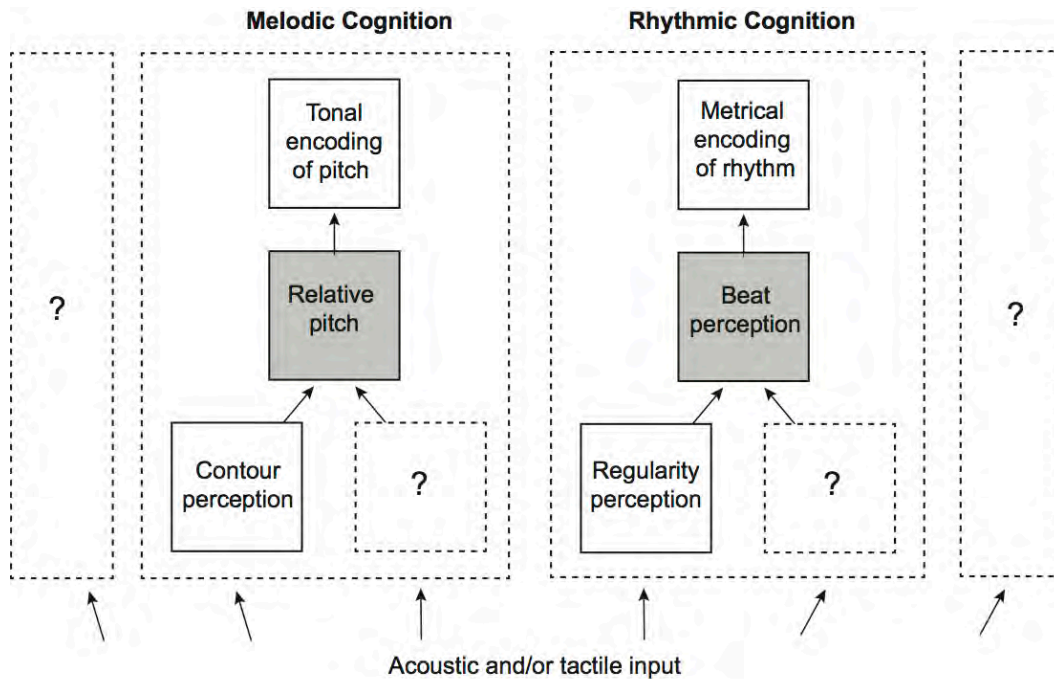

Figure 1.4. *Neurocognitive model of musicality. Diagrammatic sketch of a neurocognitive model of musicality, indicating the core components hypothesized in the current literature. Each box represents a processing component, with the arrows representing pathways of communication between processing components. Boxes with a question mark refer to other, as yet undiscovered components.*

Hypothesized components adapted from Peretz and Coltheart (2003), Honing et al. (under review), and Merchant and Honing (2014).

Is Musicality Grounded in Our Biology?

In the past decade, it has become popular to consider the origins of music from an evolutionary perspective (Cross, 2007; Justus & Hutsler, 2005; McDermott & Hauser, 2005; Vitouch & Ladinig, 2009; Wallin et al., 2000). Yet disagreement remains about the extent to which music is grounded in our biology, if it played a role in our survival as a species, and, if so, whether musicality resulted from natural or sexual selection (or even group selection; Brown, 2000).

At least three adaptationist explanations of music have been proposed. Charles Darwin (1871) was the first to suggest that sexual selection played a role in the origins of music, a view that has been revived and reevaluated in recent years (Merker, 2000; Miller, 2000; but see, e.g., Mosing et al., 2015). For Darwin, music had no survival benefits but offered a means of impressing potential partners, thereby contributing to reproductive success. Like other subsequent scholars (Brown, 2000; Mithen, 2009), Darwin argued that musical vocalizations preceded language (Fitch, 2013a). The latter view supports the idea that musicality might actually be a precursor of both music and language, the latter

recycling parts of the neural structures that evolved for musicality (see chapter 9, this volume).

Another view traces the origins of music to caregivers' music-like vocalizations to infants, which are thought to enhance parent-infant bonds, ease the burdens of caregiving, and promote infant well-being and survival (Dissanayake, 2008; Trehub, 2003). Proponents of this view see such vocalizations as having paved the way not only for language but also for music (Brown, 2000).

A third view stresses the role of music in promoting and maintaining group cohesion. Music is thought to be the social glue that enhances cooperation and strengthens feelings of unity (Cross, 2009; Merker, Madison, & Eckerdal, 2009). According to Dunbar (2012), group singing and dancing among our hominin ancestors replaced social grooming (i.e., grooming of others involving touch) as a means of maintaining social connections as groups expanded in size. Song and dance have similar neurochemical effects to social grooming, such as endorphin release (Dunbar, 2010), which has important social consequences.

A prominent nonadaptationist view considers music to be a technology or transformative invention that makes use of existing skills and has important consequences for culture and biology (Patel, 2010). In this view, music is an exaptation, spandrel, or evolutionary by-product of other skills (cf. Pinker, 1997).

This notion has parallels with the transformative control of fire by early humans that made it possible for them to cook food and obtain warmth, which also had an important cultural and biological impact (Goudsblom, 1995; Wrangham & Conklin-Brittain, 2003). Two more recent viewpoints, combining adaptive and nonadaptive perspectives, are discussed in more detail in chapters 4 and 5, this volume.

Can the Evolution of Music Cognition Be Studied?

Despite the many theories on the biological origins of music, most scholars until relatively recently were wary of the notion that music cognition could have a biological basis:

There is no reason to believe there is a universally shared, innate basis for music perception. Although the possible survival value of music has often been speculated about, music has not been around long enough to have shaped perceptual mechanisms over thousands of generations. Clearly, music is a cultural artifact, and knowledge about it must be acquired. Moreover, in contrast to speech, this knowledge is acquired relatively slowly and not equally by all individuals of a given nature. (Repp, 1991, p. 260)

This position is typical of scholarly thought over the past fifty years, with music viewed as a cultural product with no evolutionary history and no biological constraints on its manifestation.

The available unambiguous fossil record—beautiful bone flutes—dates musical activity to at least 45,000 years ago (Conard, Malina, & Münzel, 2009; Morley, 2013), a modest time frame in evolutionary terms. For comparison, most researchers date the presence of modern human language to at least 100,000 years ago (Fitch, 2017). It is impossible, however, to conclude from this that music has not been around long enough to shape perception or cognition. Vocal music and percussive use of the body leave no physical traces, so the archaeological record can only provide evidence of musical instruments, and only of instruments made of durable material such as bone. Opposing claims that “we may safely infer ... that music is among the most ancient of human cognitive traits” (Zatorre & Salimpoor, 2013, p. 10430) are equally speculative. For the moment, at least, definitive conclusions about the prehistory and origins of music cannot be formulated.

Furthermore, there is much skepticism about whether it is even possible to gain insight into the evolution of cognition in general (Bolhuis & Wynne, 2009; Honing & Ploeger, 2012; Lewontin, 1998) and, by extension, into musicality. According to Lewontin (1998), evolutionary theory rests on three principles—

variation, heredity, and natural selection—that limit scientific inquiry into cognition. To understand the evolution of cognition, it is necessary to understand the variation in cognitive traits in ancestral times. Because cognition does not fossilize, however, we cannot acquire the requisite evidence about variability (Lewontin, 1998). On the issue of the heritability of musicality, many studies provide evidence to support this (see chapter 10, this volume), but it is difficult to specify the genes because cognitive traits are polygenic. It would also be necessary to gather evidence about the possibility that cognitive traits were the target of natural selection. Without reconstructing the minds of our hunter-gatherer predecessors, for example, we can only guess at the selection pressures they faced (Bolhuis & Wynne, 2009). But these skeptical comments apply to virtually all aspects of human cognition, not just music.

It is worth noting, however, that the possible adaptive function of music is only one of several indispensable levels at which the cognitive and biological phenomena that may underlie musicality can be analyzed. In addition to the possible survival or reproductive value of music (adaptation), one can examine the neurobiological substrates (mechanisms), developmental trajectory (ontogeny), and their evolutionary history (phylogeny; see Tinbergen, 1963). For traits that are shared with other animals, the comparative approach provides a rigorous way to analyze both phylogeny (via homology) and adaptation (via

analogy). Thus, multiple divergent perspectives are necessary for understanding the full complexity of musicality, making its study a truly interdisciplinary endeavor.

A Research Agenda on Musicality

Given these considerations and as an outcome of the discussions held at the Lorentz workshop in 2014, three groups of interrelated questions arise. I present them below in the form of aims for future research in musicality.

One important question concerns the identification of the constituent components of musicality in humans. What is the most promising means of carving musicality into component skills? How can these constituent components be effectively probed in humans? What is the neural circuitry associated with the core components of musicality? How can we more clearly differentiate biological and cultural contributions to musicality?

Second, and in parallel to studying musicality in humans, the foreseen research agenda aims to investigate the core components of musicality in closely related animal species (e.g., monkeys) and distantly related animal species (e.g., parrots, songbirds, seals). The central questions in these comparative studies evolve around rhythmic and melodic cognition: What are the contributions of regularity perception and beat perception in the perception of rhythm, and to what

extent these are species dependent? What are the contributions of relative pitch and timbre on the perception of melody, and in how far are these species dependent? Can animals detect higher-order (e.g., hierarchical) patterns in sound, as humans do?

Once the main core components of musicality are identified, the stage is set to work on a phenomics of musicality, addressing questions like: How can evaluation and measurement of individual musical phenotypes be operationalized? Which genes can be associated with the constituent components of musicality?

Finally, given the acquired evidence on the components of musicality in humans, monkeys, and birds and the relationship between musicality and genetics, the aim is to combine these into an integrated model of musicality that will further constrain evolutionary theories of music and musicality.

I next elaborate on this research agenda and its aims, and make further links to the chapters that discuss these issues.

Decomposing Musicality into Constituent Components

The primary task of the proposed research agenda is to carve musicality into its constituent components using a divide-and-conquer strategy (see [figure 1.1](#)). However, our current knowledge about such musical traits is fragmentary for

animals, and there are many open questions even for humans concerning the cognitive abilities involved. Therefore, what is needed are carefully designed experiments with artificially generated stimuli that examine and compare the presence of specific traits in both humans and nonhuman animals.

While musicality is likely made up of many components, it appears to be good strategy to start with a focus on core aspects like melody and rhythmic cognition (see [figure 1.4](#)). Both domains are well suited for comparative studies, both cross-cultural and cross-species, and the nature and extent of their presence in nonhuman animals have attracted considerable debate in the recent literature. These recent discussions, combined with the availability of suitable experimental techniques for tracking these phenomena in human and nonhuman animals, make this a timely and feasible enterprise (see chapters 7, 8, and 9, this volume).

Of course, we need to remain cautious about making claims on music-specific modes of processing until more general accounts have been ruled out. It still has to be demonstrated that the constituent components of musicality, when identified, are indeed domain specific. In contrast, the argument that music is a human invention (see chapter 5, this volume) depends on the demonstration that the components of musicality are not domain specific, but each cognitively linked to some nonmusical mental ability. So while there might be quite some evidence that components of musicality overlap with nonmusical cognitive features (see

chapter 5, this volume), this is in itself no evidence against musicality as an evolved biological trait or set of traits. As in language, musicality could have evolved from existing elements that are brought together in unique ways, and that system may still have emerged as a biological product through evolutionary processes, such as natural or sexual selection. As such there is no need for musicality to be modular or show a modular structure (S. Fisher, personal communication; cf. Fodor, 1983). Alternatively, based on the converging evidence for music-specific responses along specific neural pathways, it could be that brain networks that support musicality are partly recycled for language, thus predicting more overlap than segregation of cognitive functions (see chapter 9, this volume). In fact, this is one possible route to test the Darwin-inspired conjecture that musicality precedes music and language.

Probing Melodic Cognition

Many animals—insects, fish, frogs, birds, and mammals—sing sequences of pitched melodic tones to communicate with conspecifics (Doolittle, Gingras, Endres, & Fitch, 2014; Richner, 2016). One promising way of studying the biological basis of melodic cognition is to study it in humans and birds. Humans and songbirds share many interesting similarities with regard to their auditory processing capabilities. For example, humans and European starlings (*Sturnus*

vulgaris) have similar frequency sensitivity, perceive the pitch of the missing fundamental, and parse multiple pure-tone sequences into separate auditory streams (Bregman, Patel, & Gentner, 2016). At higher levels, the musical nature of birdsong has long been appreciated by humans, and some songbirds can readily learn to discriminate and even imitate human melodic sequences (Nicolai, Gundacker, Teeselink, & Güttinger, 2014).

Given these similarities, it is surprising to find major differences in how humans and songbirds perceive sequences of tones. Humans readily recognize tone sequences that are shifted up or down in log frequency because the pattern of relative pitches is maintained (referred to as interval perception or relative pitch; see figure 1.4). In contrast, songbirds were assumed to have a strong bias to rely on absolute pitch for the recognition of tone sequences (with a pitch-shifted melody to be perceived as an altogether different melody). However, a recent study (Bregman et al., 2016) suggests that songbirds attend more to the acoustic spectral contour (the distribution of energy over different frequency bands, changing over time) than to the absolute pitch. Stimuli that preserve this shape, even when pitch cues are removed (noise-band vocoded signal), seem to allow for perceptual generalization of learned acoustic patterns. Hence it could well be that a sensitivity to spectral contour is present in both human and avian cognition of

musical signals, but that relative pitch is the preferred mode of listening for humans.

Probing Rhythmic Cognition

Most animals show at least some sort of rhythmic behavior, like walking, flying, crawling, or swimming.¹ It is hence not unnatural to think that the perception (and enjoyment) of rhythm might well be shared by most animals, as Darwin (1871) argued. While recent experimental research has been finding some support for this claim (Patel, Iversen, Bregman, & Schulz, 2009; Ravignani & Cook, 2016; Schachner, Brady, Pepperberg, & Hauser, 2009; Wilson & Cook, 2016), there are also aspects of rhythmic cognition that appear to be species specific (Fitch, 2013b), such as the ability to perceive a regular pulse in a varying rhythm (i.e., beat perception) and consequently being able to synchronize to it (see chapter 8, this volume). However, if the production of synchronized movement to sound or music is not observed in certain species, this is no evidence for the absence of beat perception. It could well be that while certain species are not able to synchronize their movements to a regular beat, they are capable of beat perception. Hence, the development of probing techniques that are not dependent on overt behavior is crucial. One possibility is the application of electrophysiological techniques (e.g., scalp-recorded evoked potentials) that were

shown to allow for a direct comparison between human and nonhuman primates (Fukushima et al., 2010; Honing, Háden, Prado, Bartolo, & Merchant, 2012; Ueno et al., 2010).

With regard to rhythmic cognition in primates, the empirical evidence suggests beat-based timing to be gradually developed, peaking in humans but present in only limited form in other nonhuman primates, while humans share interval-based timing with all nonhuman primates and related species (see figure 1.5).

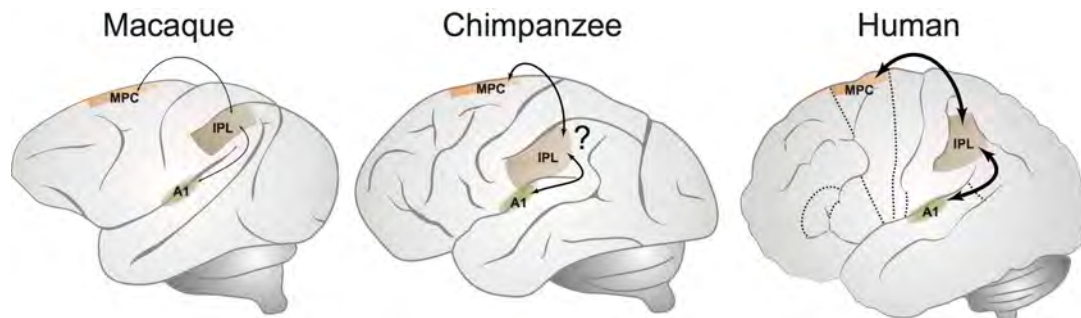

Figure 1.5. *The gradual audiomotor evolution (GAE) hypothesis. This hypothesis suggests connections between medial premotor cortex (MPC), inferior parietal lobe (IPL), and primary auditory area (A1) to be stronger in humans than in other primates (marked with solid lines), suggesting beat-based timing to have gradually evolved. Line thickness indicates the hypothesized connection strength, the question mark indicates absence of evidence (Adapted from Honing et al., under review; Merchant and Honing, 2014.)*

With regard to rhythmic cognition in birds, the literature remains partial and divided. Initially a causal link between vocal learning and beat perception and synchronization was proposed (Patel, 2006; Patel et al., 2009), associated with evolutionary modifications to the basal ganglia that play a key role in mediating a link between auditory input and motor output during learning (Petkov & Jarvis, 2014); however, other studies have questioned such an explicit link (Honing & Merchant, 2014; Wilson & Cook, 2016) or suggested at least a graded scale in avian species (ten Cate et al., 2016). Some species attend more strongly to specific local features of the individual stimuli (e.g., the exact duration of time intervals) rather than the overall regularity of the stimuli, a main feature human listeners attend to; (van der Aa, Honing, & ten Cate, 2015). These findings call for a reexamination of the nature and mechanisms underlying rhythmic cognition and its core components such as regularity and beat perception (see figure 1.4).

Operationalizing the Musical Phenotype

A comparative approach to musicality faces numerous challenges, including the identification of candidate skills and credible means of distinguishing biological from cultural contributions to human musicality. Nevertheless, consensus is growing that musicality has deep biological foundations, based on accumulating evidence for the involvement of genetic variation (Liu et al., 2016; Oikkonen,

Onkamo, Järvelä, & Kanduri, 2016; Peretz, 2016). Recent advances in molecular technologies provide an effective way of exploring these biological foundations. Next to examining clustering in families and co-occurrence in twins of extreme levels of musical ability, genome-wide association studies offer a promising route to capture the polymorphic content of a large phenotyped population sample. The success of genetic studies of musical ability is, however, critically dependent on a robust, objective, and reliable measure of the musicality phenotype, the primary aim of this research agenda. But once a small set of reliably measurable core components is identified, opportunities to administer standardized aptitude tests online (using web-based or gaming techniques, for example) provide an important step toward high-powered genome-wide screens to be able to analyze musical phenotypes (see chapter 10, this volume).

Constraining Evolutionary Theories of Music and Musicality

While I have argued that the comparative method is an effective strategy in avoiding “just-so stories” on the evolution of music, the ultimate aim is to arrive at a neurocognitive model of musicality that will further constrain theories of music and musicality (see chapters 11 through 13, this volume). Fitch (in chapter 2, this volume) and Merker, Morley, and Zuidema (in chapter 3, this volume)

make an important first step in identifying these constraints. In addition to studying the cognitive and biological aspects of musicality, scholars of the history of science are in a position to evaluate and critically situate recent developments in the longer tradition of the study of the origins of music, spanning the eighteenth century (e.g., Rousseau, Rameau), nineteenth century (e.g., Darwin, Spencer), and twentieth century (e.g., Stumpf, Merker, Brown). (A fine example of this is in chapter 14, this volume.)

Summary

The aim of the research agenda outlined in this chapter is threefold. The primary aim is to identify the basic neurocognitive mechanisms that constitute musicality, as well as effective ways of studying these in human and nonhuman animals. The second aim is to develop a comprehensive operational tool for the analysis of musical phenotypes that will be able to identify and define the biological basis of musicality. Based on the outcome of the first two aims, the third aim is to develop an integrated neurocognitive model of musicality that will further constrain existing evolutionary theories of music and musicality.

Acknowledgments

This chapter is based on material that served as a starting point for Honing et al. (2015) and benefited from the feedback of Carel ten Cate, Isabelle Peretz, and Sandra Trehub. W. Tecumseh Fitch is thanked for his comments on an earlier version of this chapter. The preparation of this chapter (and the book as a whole) was supported by a Distinguished Lorentz Fellowship granted to H.H. by the Lorentz Center for the Sciences and the Netherlands Institute for Advanced Study in the Humanities and Social Sciences and a Horizon grant (317-70-010) of the Netherlands Organization for Scientific Research.

Note

1. The specific question of whether animals can detect regularity in a stimulus and synchronize their own behavior to arbitrary rhythmic patterns got sudden attention with the discovery of Snowball, a sulfur-crested cockatoo that could entrain head and body movements with the beat in several popular songs (Patel, Iversen, Bregman, & Schulz, 2009). Parrots such as Snowball are vocal learners, and vocal learning is associated with evolutionary modifications to the basal ganglia, which play a key role in mediating a link between auditory input and motor output during learning (Petkov & Jarvis, 2014). Because such linkage

between auditory and motor areas in the brain is also required for beat entrainment, Patel (2006) suggested that only vocal learning species might be able to show beat perception (see chapters 7 and 8, this volume).

References

- <bok>Blacking, J. (1973). *How musical is man? The Jessie and John Danz Lectures*. Seattle: University of Washington Press.</bok>
- <jrn>Bolhuis, J. J., & Wynne, C. D. L. (2009). Can evolution explain how minds work? *Nature*, 458(7240), 832–833. doi:10.1038/458832a</jrn>
- <jrn>Bregman, M. R., Patel, A. D., & Gentner, T. Q. (2016). Songbirds use spectral shape, not pitch, for sound pattern recognition. *Proceedings of the National Academy of Sciences of the United States of America*, 113(6), 1666–1671. doi:10.1073/pnas.1515380113</jrn>
- <edb>Brown, S. (2000). The “musilanguage” model of music evolution. In N. Wallin, S. Brown, & B. Merker (Eds.), *The origins of music* (pp. 271–300). Cambridge, MA: MIT Press.</edb>
- <jrn>Brown, S., & Jordania, J. (2011). Universals in the world’s musics. *Psychology of Music*, 41(2), 229–248. doi:10.1177/0305735611425896</jrn>

- <eref>Brown, S., & Savage, P. E., Ko, AM-S., Stoneking, M., Ko, Y-C., Loo, J-H., & Trejaut, J. A. (2014). Correlations in the population structure of music, genes and language. *Proceedings of the Royal Society of London B: Biological Sciences*, 281(1774): 20132072.
<http://doi.org/http://dx.doi.org/10.1098/rspb.2013.2072></eref>
- <jrn>Call, J., & Tomasello, M. (2008). Does the chimpanzee have a theory of mind? Thirty years later. *Trends in Cognitive Sciences*, 12(5), 187–192.
doi:10.1016/j.tics.2008.02.010</jrn>
- <jrn>Conard, N. J., Malina, M., & Münzel, S. C. (2009). New flutes document the earliest musical tradition in southwestern Germany. *Nature*, 460(7256), 737–740. doi:10.1038/nature08169</jrn>
- <edb>Cross, I. (2007). Music and cognitive evolution. In R. I. M. Dunbar & L. Barrett (Eds.), *Oxford handbook of evolutionary psychology* (pp. 649–667). Oxford: Oxford University Press.</edb>
- <edb>Cross, I. (2009). The nature of music and its evolution. In S. Hallam, I. Cross, & M. Thaut (Eds.), *Oxford handbook of music psychology* (pp. 3–13). Oxford: Oxford University Press.</edb>
- <bok>Darwin, C. (1871). *The descent of man, and selection in relation to sex*. London: John Murray.</bok>

<jrn>de Waal, F. B. M., & Ferrari, P. F. (2010). Towards a bottom-up perspective on animal and human cognition. *Trends in Cognitive Sciences*, 14(5), 201–207. doi:10.1016/j.tics.2010.03.003</jrn>

<bok>de Waal, F. B. M., & Ferrari, P. F. (2012). *The primate mind*. Cambridge, MA: Harvard University Press.</bok>

<bok>Deutsch, D. (2013). *The psychology of music*. (3rd ed.). London: Academic Press. doi:10.1016/B978-0-12-381460-9.00007-9</bok>

<jrn>Dissanayake, E. (2008). If music is the food of love, what about survival and reproductive success? *Musicae Scientiae* [Special issue], 12 (1), 169–195.</jrn>

<conf>Doolittle, E. L., Gingras, B., Endres, D. M., & Fitch, W. T. (2014). Overtone-based pitch selection in hermit thrush song: Unexpected convergence with scale construction in human music. *Proceedings of the National Academy of Sciences*, 11(46), 1–6.
<http://doi.org/10.1073/pnas.1406023111></conf>

<jrn>Dunbar, R. I. M. (2010). The social role of touch in humans and primates: Behavioural function and neurobiological mechanisms. *Neuroscience and Biobehavioral Reviews*, 34(2), 260–268.
doi:10.1016/j.neubiorev.2008.07.001</jrn>

- <edb>Dunbar, R. I. M. (2012). On the evolutionary function of song and dance. In N. Bannan (Ed.), *Music, language, and human evolution* (pp. 201–214). Oxford: Oxford University Press.</edb>
- <jrn>Fitch, W. T. (2006). The biology and evolution of music: A comparative perspective. *Cognition*, 100(1), 173–215. doi:10.1016/j.cognition.2005.11.009</jrn>
- <bok>Fitch, W. T. (2010). *The evolution of language*. Cambridge: Cambridge University Press.</bok>
- <edb>Fitch, W. T. (2013a). Musical protolanguage: Darwin’s theory of language evolution revisited. In J. J. Bolhuis & M. Everaert (Eds.), *Birdsong, speech, and language: Exploring the evolution of mind and brain* (pp. 489–503). Cambridge, MA: MIT Press.</edb>
- <jrn>Fitch, W. T. (2013b). Rhythmic cognition in humans and animals: Distinguishing meter and pulse perception. *Frontiers in Systems Neuroscience*, 7, 1–16. doi:10.3389/fnsys.2013.00068</jrn>
- <jrn>Fitch, W. T. (2017). Empirical approaches to the study of language evolution. *Psychonomic Bulletin and Review*, 24, 3–33. doi:10.3758/s13423-017-1236-5</jrn>
- <bok>Fodor, J. A. (1983). *The modularity of mind*. Cambridge, MA: MIT Press;

10.2307/2184717</bok>

<jrn>Fukushima, H., Hirata, S., Ueno, A., Matsuda, G., Fuwa, K. K., Sugama, K., et al. (2010). Neural correlates of face and object perception in an awake chimpanzee (*Pan troglodytes*) examined by scalp-surface event-related potentials. *PLoS One*, 5(10), e13366.
doi:10.1371/journal.pone.0013366</jrn>

<bok>Goudsblom, J. (1995). *Fire and civilization*. London: Penguin Books.</bok>

<bok>Hallam, S., Cross, I., & Thaut, M. (2009). *Oxford handbook of music psychology*. Oxford: Oxford University Press.</bok>

<jrn>Hoeschele, M., Cook, R. G., Guillette, L. M., Hahn, A. H., & Sturdy, C. B. (2014). Timbre influences chord discrimination in black-capped chickadees (*Poecile atricapillus*) but not humans (*Homo sapiens*). *Journal of Comparative Psychology*, 128(4), 387–401.
doi:10.1037/a0037159</jrn>

<jrn>Honing, H. (2012). Without it no music: Beat induction as a fundamental musical trait. *Annals of the New York Academy of Sciences*, 1252(1), 85–91. doi:10.1111/j.1749-6632.2011.06402.x</jrn>

<bok>Honing, H. (2013). *Musical cognition: A science of listening*. New

Brunswick, NJ: Transaction Publishers.</bok>

<jrn>Honing, H., Bouwer, F. L., Prado, L., & Merchant, H. (under review).

Rhesus monkeys (*Macaca mulatta*) sense isochrony in rhythm, but not the beat. *Cortex*.</jrn>

<jrn>Honing, H., Háden, G. P., Prado, L., Bartolo, R., & Merchant, H. (2012).

Rhesus monkeys (*Macaca mulatta*) detect rhythmic groups in music, but not the beat. *PLoS One*, 7(12), 1–10.

doi:10.1371/journal.pone.0051369</jrn>

<jrn>Honing, H., & Merchant, H. (2014). Differences in auditory timing between

human and non-human primates. *Behavioral and Brain Sciences*, 27(6), 557–558.</jrn>

<jrn>Honing, H., & Ploeger, A. (2012). Cognition and the evolution of music:

Pitfalls and prospects. *Topics in Cognitive Science*, 4(4), 513–524.

doi:10.1111/j.1756-8765.2012.01210.x</jrn>

<jrn>Honing, H., ten Cate, C., Peretz, I., & Trehub, S. E. (2015). Without it no

music: Cognition, biology and evolution of musicality. *Philosophical Transactions of the Royal Society of London B: Biological Sciences*,

370(1664), 20140088. doi:10.1098/rstb.2014.0088</jrn>

<jrn>Justus, T., & Hutsler, J. (2005). Fundamental issues in the evolutionary

psychology of music: Assessing innateness and domain specificity. *Music Perception*, 23(1), 1–27.</jrn>

<edb>Lewontin, R. (1998). The evolution of cognition: Questions we will never answer. In D. Scarborough & S. Sternberg (Eds.), *Methods, models, and conceptual issues: An invitation to cognitive science* (pp. 107–132). Cambridge, MA: MIT Press.</edb>

<jrn>Liu, X., Kanduri, C., Oikkonen, J., Karma, K., Raijas, P., Ukkola-Vuoti, L., et al. (2016, February). Detecting signatures of positive selection associated with musical aptitude in the human genome. *Scientific Reports*, 6, 21198. doi:10.1038/srep21198</jrn>

<jrn>Lomax, A., & Berkowitz, N. (1972). The evolutionary taxonomy of culture. *Science*, 177(4045), 228–239. doi:10.1126/science.177.4045.228</jrn>

<jrn>McDermott, J. H., & Hauser, M. D. (2005). The origins of music: Innateness, uniqueness, and evolution. *Music Perception*, 23(1), 29–59.</jrn>

<jrn>Mendoza, G., & Merchant, H. (2014). Motor system evolution and the emergence of high cognitive functions. *Progress in Neurobiology*, 122, 73–93. doi:10.1016/j.pneurobio.2014.09.001</jrn>

<jrn>Merchant, H., & Honing, H. (2014). Are non-human primates capable of

rhythmic entrainment? Evidence for the gradual audiomotor evolution hypothesis. *Frontiers in Auditory Cognitive Neuroscience*, 7(274), 1–8.
doi:10.3389/fnins.2013.00274</jrn>

<edb>Merker, B. (2000). Synchronous chorusing and human origins. In N. L. Wallin, B. Merker, & S. Brown (Eds.), *The origins of music* (pp. 315–327). Cambridge, MA: MIT Press.</edb>

<jrn>Merker, B., Madison, G. S., & Eckerdal, P. (2009). On the role and origin of isochrony in human rhythmic entrainment. *Cortex*, 45(1), 4–17.
doi:10.1016/j.cortex.2008.06.011</jrn>

<edb>Miller, G. F. (2000). Evolution of human music through sexual selection. In N. L. Wallin, B. Merker, & S. Brown (Eds.), *The origins of music* (pp. 329–360). Cambridge, MA: MIT Press.</edb>

<jrn>Mithen, S. J. (2009). The music instinct: The evolutionary basis of musicality. *Annals of the New York Academy of Sciences*, 1169, 3–12.</jrn>

<bok>Morley, I. (2013). *The prehistory of music: Human evolution, archaeology, and the origins of musicality*. Oxford: Oxford University Press.</bok>

<jrn>Mosing, M. A., Verweij, K. J. H., Madison, G., Pedersen, N. L., Zietsch, B. P., & Ullén, F. (2015). Did sexual selection shape human music? Testing

predictions from the sexual selection hypothesis of music evolution using a large genetically informative sample of over 10,000 twins. *Evolution and Human Behavior*, 36(5), 359–366.

doi:10.1016/j.evolhumbehav.2015.02.004</jrn>

<jrn>Nettl, B. (2006). Response to Victor Grauer: On the concept of evolution in the history of ethnomusicology. *World of Music*, 48(2), 59–72.</jrn>

<jrn>Nicolai, J., Gundacker, C., Teeselink, K., & Güttinger, H. R. (2014). Human melody singing by bullfinches (*Pyrrhula pyrrula*) gives hints about a cognitive note sequence processing. *Animal Cognition*, 17(1), 143–155.

doi:10.1007/s10071-013-0647-6</jrn>

<jrn>Oikkonen, J., Onkamo, P., Järvelä, I., & Kanduri, C. (2016). Convergent evidence for the molecular basis of musical traits. *Scientific Reports*, 6, 1–10. doi:10.1038/srep39707</jrn>

<jrn>Patel, A. D. (2006). Musical rhythm, linguistic rhythm, and human evolution. *Music Perception*, 24(1), 99–104.

doi:10.1525/mp.2006.24.1.99</jrn>

<edb>Patel, A. D. (2010). Music, biological evolution, and the brain. In M. Bailar (Ed.), *Emerging disciplines* (pp. 1–37). Houston, TX: Rice University Press.</edb>

- <jrn>Patel, A. D., Iversen, J. R., Bregman, M. R., & Schulz, I. (2009). Experimental evidence for synchronization to a musical beat in a nonhuman animal. *Current Biology*, *19*(10), 827–830. doi:10.1016/j.cub.2009.03.038</jrn>
- <jrn>Peretz, I. (2016). Neurobiology of congenital amusia. *Trends in Cognitive Sciences*, *20*(11), 857–867. doi:10.1016/j.tics.2016.09.002</jrn>
- <jrn>Peretz, I., & Coltheart, M. (2003). Modularity of music processing. *Nature Neuroscience*, *6*(7), 688–691. doi:10.1038/nn1083</jrn>
- <jrn>Peretz, I., & Zatorre, R. J. (2005). Brain organization for music processing. *Annual Review of Psychology*, *56*, 89–114. doi:10.1146/annurev.psych.56.091103.070225</jrn>
- <jrn>Petkov, C. I., & Jarvis, E. D. (2014). The basal ganglia within a cognitive system in birds and mammals. *Behavioral and Brain Sciences*, *37*(6), 568–604. doi:10.1017/S0140525X13004160</jrn>
- <bok>Pinker, S. (1997). *How the mind works*. New York: Norton</bok>
- <jrn>Ravignani, A., & Cook, P. F. (2016). The evolutionary biology of dance without frills. *Current Biology*, *26*(19), R878–R879. doi:10.1016/j.cub.2016.07.076</jrn>

- <edb>Repp, B. H. (1991). Some cognitive and perceptual aspects of speech and music. In J. Sundberg, L. Nord, & R. Carlson (Eds.), *Music, language, speech and brain* (pp. 257–268). Stockholm: Macmillan.</edb>
- <jrn>Richner, H. (2016). Interval singing links to phenotypic quality in a songbird. *Proceedings of the National Academy of Sciences of the United States of America*, *113*(45), 12763–12767.
doi:10.1073/pnas.1610062113</jrn>
- <jrn>Rilling, J. K., Glasser, M. F., Preuss, T. M., Ma, X., Zhao, T., Hu, X., et al. (2008). The evolution of the arcuate fasciculus revealed with comparative DTI. *Nature Neuroscience*, *11*(4), 426–428. doi:10.1038/nn2072</jrn>
- <jrn>Savage, P. E., Brown, S., Sakai, E., & Currie, T. E. (2015). Statistical universals reveal the structures and functions of human music. *Proceedings of the National Academy of Sciences of the United States of America*, *112*(29), 8987–8992. doi:10.1073/pnas.1414495112</jrn>
- <jrn>Schachner, A., Brady, T. F., Pepperberg, I. M., & Hauser, M. D. (2009). Spontaneous motor entrainment to music in multiple vocal mimicking species. *Current Biology*, *19*(10), 831–836.
doi:10.1016/j.cub.2009.03.061</jrn>
- <jrn>Spierings, M. J., & ten Cate, C. (2014). Zebra finches are sensitive to

prosodic features of human speech. *Proceedings of the Royal Society B: Biological Sciences* 281(1787). doi:10.1098/rspb.2014.0480</jrn>

<jrn>ten Cate, C., Spierings, M., Hubert, J., & Honing, H. (2016, May). Can birds perceive rhythmic patterns? A review and experiments on a songbird and a parrot species. *Frontiers in Psychology*, 7, 1–14.
doi:10.3389/fpsyg.2016.00730</jrn>

<jrn>Tinbergen, N. (1963). On aims and methods of ethology. *Zeitschrift für Tierpsychologie*, 20, 410–433.</jrn>

<jrn>Trainor, L. J. (2008). Science and music: The neural roots of music. *Nature*, 453, 598–599. doi:10.1038/453598a</jrn>

<jrn>Trehub, S. E. (2003). The developmental origins of musicality. *Nature Neuroscience*, 6, 669–673.</jrn>

<jrn>Trehub, S. E. (2015). Cross-cultural convergence of musical features. *Proceedings of the National Academy of Sciences of the United States of America*, 112(29), 8809–8810. doi:10.1073/pnas.1510724112</jrn>

<jrn>Ueno, A., Hirata, S., Fuwa, K. K., Sugama, K., Kusunoki, K., Matsuda, G., et al. (2010). Brain activity in an awake chimpanzee in response to the sound of her own name. *Biology Letters*, 6(3), 311–313.
doi:10.1098/rsbl.2009.0864</jrn>

- <jrn>van der Aa, J., Honing, H., & ten Cate, C. (2015). The perception of regularity in an isochronous stimulus in zebra finches (*Taeniopygia guttata*) and humans. *Behavioural Processes*, *115*, 37–45.
doi:10.1016/j.beproc.2015.02.018</jrn>
- <jrn>Vitouch, O., & Ladinig, O. (2009). Preface to Special Issue: Music and evolution. *Musicae Scientiae*, *13*(2 Suppl.), 7–11.
doi:10.1177/1029864909013002021</jrn>
- <bok>Wallin, N., Merker, B., & Brown, S. (Eds.). (2000). *The origins of music*. Cambridge, MA: MIT Press.</bok>
- <jrn>Wilson, M., & Cook, P. F. (2016). Rhythmic entrainment: Why humans want to, fireflies can't help it, pet birds try, and sea lions have to be bribed. *Psychonomic Bulletin and Review*. doi:10.3758/s13423-016-1013-x</jrn>
- <jrn>Winkler, I., Háden, G. P., Ladinig, O., Sziller, I., & Honing, H. (2009). Newborn infants detect the beat in music. *Proceedings of the National Academy of Sciences of the United States of America*, *106*(7), 2468–2471.
doi:10.1073/pnas.0809035106</jrn>
- <jrn>Wrangham, R., & Conklin-Brittain, N. (2003). Cooking as a biological trait. *Comparative Biochemistry and Physiology. Part A, Molecular and*

Pre-print of: Honing, H. (2018, in press). Musicality as an upbeat to music: Introduction and research agenda. In H. Honing (Ed.), *The Origins of Musicality*. Cambridge, Mass.: MIT Press.

Integrative Physiology, 136, 35–46. doi:10.1016/S1095-6433(03)00020-

5</jrn>

<jrn>Zatorre, R. J. (2005). Music the food of neuroscience? *Nature*, 434, 312–
315.</jrn>

<jrn>Zatorre, R. J., & Salimpoor, V. N. (2013). From perception to pleasure:
Music and its neural substrates. *Proceedings of the National Academy of
Sciences of the United States of America*, 110(Suppl.), 10430–10437.
doi:10.1073/pnas.1301228110</jrn>